

MultiFuel Boiler Dimensions

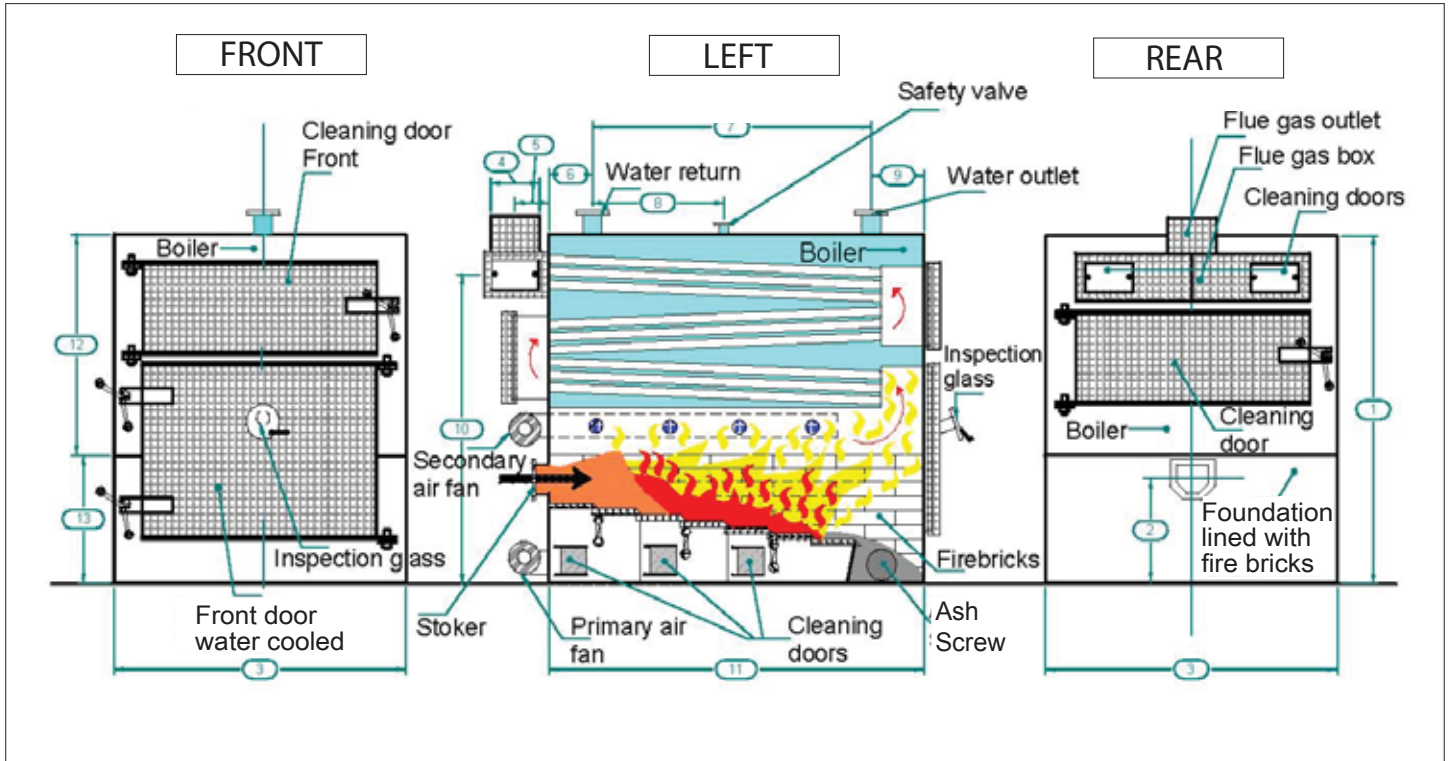

BOILER SIZE	kW BTU	100	160	200	300	400	500	600	750	1000	1300	1500	2000	2600	3000	3500
		341,200	545,920	682,400	1,023,600	1,364,800	1,706,000	2,047,200	2,559,000	3,412,000	4,435,600	5,118,000	6,824,000	8,871,200	10,236,000	11,942,000
1 Overall height	in	88.4	94.5	93.1	103.9	108.9	106.5	106.3	121.5	128.7	144.9	152.8	158.9	159.6	206.3	206.3
2 Floor to CL stoker	in	30.9	35.8	35.8	34.6	35.0	35.0	36.6	43.3	43.3	43.3	43.3	51.2	51.8	64.6	64.6
3 Overall width	in	39.0	36.6	48.7	51.8	53.9	60.4	60.4	60.4	67.8	67.8	67.8	92.1	92.1	106.3	106.3
4 Flue diameter	in	8.5	8.5	8.5	9.8	9.8	9.8	11.8	11.8	11.8	13.8	13.8	23x23	23x23	19.7	21.7
5 CL Flue to boiler back	in	9.8	10.6	9.8	9.4	9.4	9.4	9.4	13.8	11.8	12.6	12.6	23.6	23.6	15.7	15.7
6 Boiler back-CL return flange	in	12.6	12.6	15.7	13.0	14.6	21.2	15.4	20.3	28.7	28.7	28.7	66.1	66.1	76.0	76.0
7 CL outlet-inlet flanges	in	37.4	55.1	59.1	53.9	56.7	52.9	63.0	77.6	71.1	78.7	78.7	88.6	88.6	90.6	90.6
8 CL relief flange-inlet flange	in	14.2	23.6	29.5	26.8	27.2	26.5	31.5	41.1	38.2	39.4	39.4	44.5	44.5	54.3	54.3
9 Front to CL outlet flange	in	9.4	21.7	15.7	22.4	18.1	28.9	24.8	31.3	28.7	28.3	28.3	23.6	23.6	23.6	23.6
10 Floor to CL smoke box	in	78.7	80.7	86.4	92.1	102.0	100.8	100.4	112.4	117.3	133.5	104.3	100.4	101.2	174.0	174.0
11 Overall length	in	69.7	99.0	90.6	99.2	99.2	109.4	109.4	138.9	139.0	145.7	145.7	178.3	178.3	190.2	190.2
12 Overall height	in	50.0	51.2	50.0	60.8	65.7	63.4	63.4	72.8	72.8	89.0	96.9	96.7	96.7	129.9	129.9
13 Combustion box height	in	38.4	43.3	43.1	43.1	43.1	43.1	42.9	48.6	55.9	55.9	55.9	62.2	63.0	76.4	76.4
Stoker screw dia.	in	5.9	5.9	5.9	7.1	7.1	7.1	7.9	9.8	9.8	9.8	9.8	11.8	11.8	15.7	15.7
Ash screw dia.	in	5.9	5.9	5.9	5.9	5.9	5.9	5.9	5.9	5.9	5.9	5.9	5.9	5.9	5.9	5.9
Outlet flange (PN 16)	in	2.0	2.0	2.5	2.5	3.0	4.0	4.0	4.0	5.0	6.0	6.0	8.0	8.0	8.0	8.0
Return flange (PN-16)	in	2.0	2.0	2.5	2.5	3.0	4.0	4.0	4.0	5.0	6.0	6.0	8.0	8.0	8.0	8.0
Safety valve flange (PN-16)	in	1.5	1.5	1.5	1.5	1.5	1.5	1.5	1.5	2.0	2.0	2.0	5.0	6.0	6.0	6.0
Boiler weight empty	lb	3300	3960	4180	4620	5280	7260	7920	8800	12760	15400	16940	22440	24200	30800	34100
Bottom section wt.	lb	2860	3300	3300	3960	6380	6600	7700	8800	9240	12100	12980	17600	17600	26400	28600
Water content	gal	264	304	330	370	476	608	687	819	1374	1321	1480	2774	2642	4412	4359
Water content	lb	2193	2522	2741	3070	3947	5044	5701	6798	11403	10964	12280	23025	21929	36621	36182
Test pressure	psi	76.4	76.4	76.4	76.4	76.4	76.4	76.4	76.4	76.4	76.4	76.4	76.4	76.4	76.4	76.4
Design pressure	psi	51.5	51.5	51.5	51.5	51.5	51.5	51.5	51.5	51.5	51.5	51.5	51.5	51.5	51.5	51.5
Door swing radius	in	21.7	27.6	27.6	31.5	31.5	39.4	45.3	43.3	43.3	45.3	45.3	45.3	45.3	47.2	47.2

MultiFuel Mini Dimensions

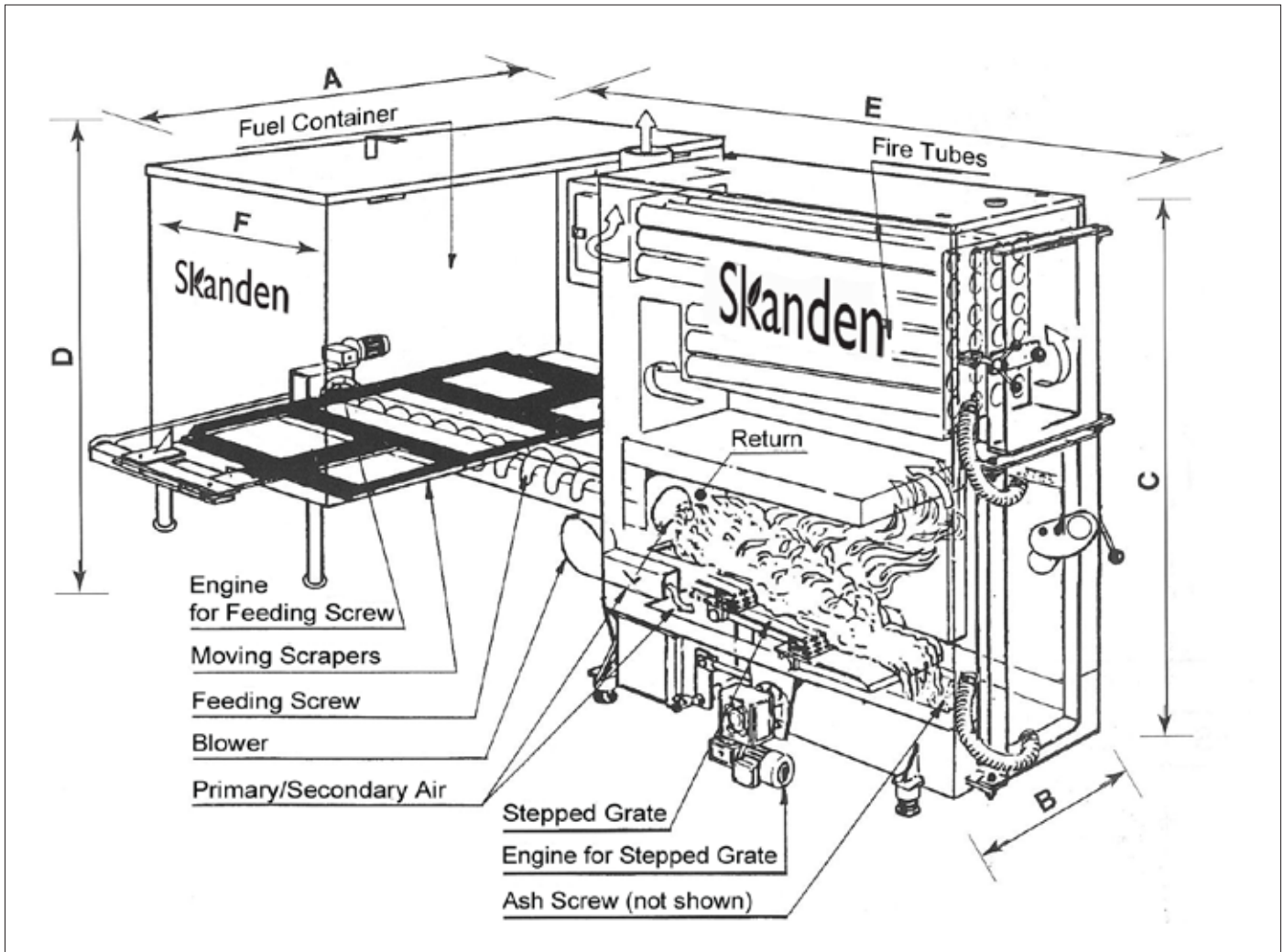

TYPE	OUTPUT BTUs	PRINCIPLE DIMENSIONS (In Inches)							
		A	B	C	D	E	F	Pipe Stub (forward return)	Fire Tubes
20kW	68,000	23.6	27.6	49.2	52.4	106.3	25.6	2"	8.5
30kW	102,000	23.6	27.6	55.9	52.4	106.3	25.6	2"	8.5
60kW	205,000	23.6	27.6	55.9	52.4	106.3	25.6	2"	8.5
80kW	273,000	23.6	27.6	55.9	52.4	106.3	25.6	2"	8.5

Skanden

Local, renewable energy made easy.

207-512-5699 info@skanden.com www.skanden.com